

盘式滑环系列

施加杰

电话: 0571-86936357

传真: 0571-86496785

手机: 13656660180

邮箱: sales6@hzqs.com

QQ: 1399486506

网址: www.hzqs.com

Pancake Slip Ring

特点 Features

- 厚度小, 节省空间
Low in height
- 动力及信号混走
Combination of power and signal transmission
- 抗干扰设计
Anti-interference

可选项 Optionals

- 导线长度 Lead length
- 端子类型 Terminal type
- 安装方式 Way of installation

典型应用 Typical Applications

- 旋转门 Revolving door

SRP040-3P/17S 盘式导电滑环

SRP040-3P/17S Pancake Slip Ring

外形尺寸 Outline Dimension

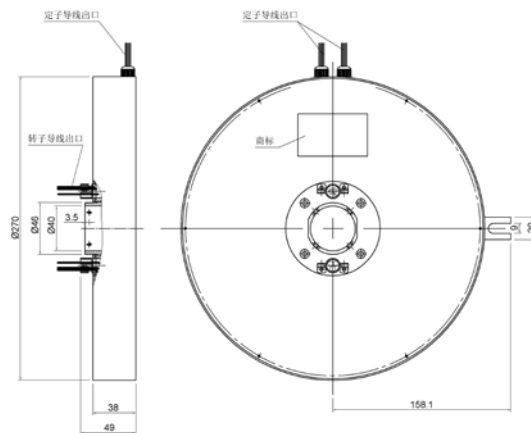

电气技术指标 Electrical data

参数 Specification	数值 Values
环道数 NO. of Rings	20
额定电流 Rated Current	15A/环, 3环; 5A/环, 17环 15A/ring (power), 3 rings; 5A/ring (signal), 17rings
导线规格 Lead Size	镀锡导线、铁氟龙绝缘AWG16 tin plated, PTFE insulated or PVC
导线长度 Lead Length	500/1000mm或根据客户要求提供 500/1000mm (or as request)
绝缘体强度 Dielectric Strength	500VAC@50Hz, 60S
绝缘电阻 Insulation Resistance	≥ 1000MΩ/500VDC

机械技术指标 Mechanical data

参数 Specification	数值 Values
工作速度 Operating Speed	0~100rpm
工作温度 Temperature Range	-40°C ~ +80°C
工作湿度 Operating Humidity	60%RH 或更高 60%RH or higher
接触材料 Contact Material	贵金属 Precious Metals
壳体材料 Housing Material	铝合金 Aluminum
防护等级 Protection level	IP 5 1